



Howden

Air and Gas Handling in
Mining and Mineral Processing



Solutions for
the **Mining**
Industry



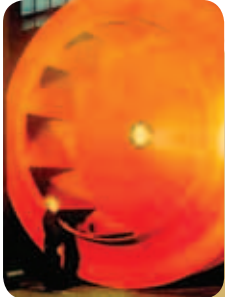

Howden Australia is
a Service Provider to
Asia Pacific and Pacific
Rim Heavy Industry.



The Howden Group has been operating throughout the world for 150 years with manufacturing companies or offices and Agents Representative in most countries. The activities of the Group are coordinated on a regional and market basis, Howden Australia being the principal unit of the Howden Power division in the Asia-Pacific and Pacific Rim region, handling heavy to medium air and gas handling products for a range of industries.

The original organisation, James Howden and Co. Ltd, was founded in Scotland in 1854 and grew up along with the steamship industry of Clydeside as a boiler, engine, heat transfer and draught plant supplier. The company's operations expanded over the years to become the major supplier of air and gas handling equipment to the Mining, Power Generation, Steel, Alumina, Cement, Oil and Gas, Paper Mill, Co-Generation Sugar Mill and generally most heavy industries.

Howden is currently the world's leading supplier of air and gas handling equipment and the world's largest supplier of industrial fans. By far the largest global installed base, the company has grown by both internal development and acquisition. Key products from the following well-known air and gas handling companies are now incorporated within the Howden product range:

Howden Product Range

- | | | |
|------------------------------|-------------------------------|-------------------------|
| Aerex Fans | Godfrey Blowers | Sirocco Fans |
| Aerodyne Fans | Howden Fans | Stork Fans |
| Airtech Fans | Howden Heaters | Sturtevant Fans |
| American Blower | Howden Process Compressors | Tallares Sanchez Luengo |
| American Standard | Howden Sirocco Fans & Heaters | (TSL) Elements |
| Berry Fans | James Howden Fans | Turbowerke Meissen Fans |
| Buffalo Fans | Joy Fans | Variax Fans |
| Buffalo Forge Fans | Joy Green Fans | Ventilatoren Fans |
| Burton Corblin Compressors | Majax Fans | Ventilateurs Neu Fans |
| Canadian Blower | Meissen Fans | Voith Fans |
| Carter Fans | Neu Fans | Wolf Fans |
| Cementation Engineering Fans | Nordisk Fans | Westinghouse Sturtevant |
| Davidson Fans | Novenco Fans | Wheeler Fans |
| Donkin Fans | Pitstock Fans | |
| Donkin Blowers | Phoenix Fans | |
| Engart Fans | Powermax Fans | |
| Fantecnic Fans | Sheldon Fans | |
- And many more company names and brands.....**

The 3,000 global Howden staff members are connected with modern communication systems and have personal contact with tens of thousand end users and plant operators.

R&D and administration of the core technology are entrusted to a number of "Centres of Excellence" in various locations around the world. Engineering of the Howden products for specific customer applications is done mainly on a local or regional basis and manufacture is carried out in the most cost-effective location depending on the installation site.

Howden Group companies have operated in Australia for more than 50 years. In addition to being the supplier of choice in the local market, Howden Australia is the major service provider and product supplier.

Howden Australia Pty Limited

Howden Australia Pty Limited is the heavy to medium fan, air preheater and acoustic products division of Howden in Asia Pacific and Pacific Rim with its Head Office in Sydney. Howden Australia offers a comprehensive package that includes customised engineering, project management, manufacture, supply, service solution engineering and site management service. The Company employs a team of experienced professional mechanical and structural engineers who are fully conversant with modern design techniques including finite element analysis (FEA) and computer aided design (CAD). Specialised facilities are available in Sydney for full-size and scale model aerodynamic testing of fans and blowers. The Company also has equipment for stress, acoustic and vibration measurement. In addition to the above, on-site performance testing of equipment can be conducted to internationally recognised standards using portable equipment.

Equipment Design and Selection:

An important issue when supplying new or retrofit equipment is the ability to assess the needs of the customer so that equipment packages that are best suited to these needs and give maximum cost recovery, are offered.

Howden Australia engineers liaise closely with the customer and evaluate sites to obtain data and an in-depth understanding of the process. Using this knowledge together with available information on operating costs, the most cost-effective solutions are developed. In the case of retrofits this often means maximising the use of existing equipment and minimising the extent of new equipment supply.

Howden Australia uses sophisticated computer programs, developed over many years, to select both fans and airheaters. This software makes it possible to quickly examine multiple solutions each with particular merits and thereby select the best equipment for the job. It should be noted that we custom engineer our products for each application and do not compromise performance in the interests of ease of engineering.

Proposal drawings may be prepared and detailed quotations submitted. These can include commercial evaluations for the purpose of purchase justification.

Feasibility studies are also carried out if required.

Project Capability

Project capability extends from the supply of flange-to-flange items of equipment to complete turn-key installations. In the case of fans this might include silencers, ductwork, main drive motors, electrical switchboards and control panels, instrumentation and condition monitoring, civil works and associated buildings. Howden Australia also engineers and manages major rehabilitation works.

The project management function includes the following:

- Planning and scheduling of resources and manpower using up-to-date computer techniques.
- Engineering, design, and drafting.
- Procurement.
- Negotiation and control of sub-contracts.
- Manufacture and supply of equipment. Where appropriate re-work of existing equipment.
- Site management and supervision of erection and commissioning.

Engineering

All products supplied by Howden Australia Pty Ltd are fully designed and drafted in our offices in Sydney. A team of highly qualified and experienced professional engineers use the latest computer based methods to ensure that the designs are optimal. All drafting is done using AutoCAD™. The most recent version of this program is implemented as soon as the drafters can practicably be retrained.

Key customer drawings can be supplied in AutoCAD™ or DXF format. If necessary these can be transmitted by e-mail. In the formative stages of the design we encourage interactive information / drawing exchange with the customer to ensure that our equipment is integrated into the overall plant in the best possible way.

Contract Management:

Contract administration for all contracts is carried out from our Sydney office. Procedures developed specifically to suit the Howden product range are used to optimise efficiency.

A competitive but fair approach is adopted with regard to sub-contractors. Sub-contractors are selected in every case on the basis of their ability to deliver a quality product or service on time and their prices must reflect an efficient operation.

New suppliers of materials and manufacturers of equipment, regardless of location, are checked to ensure they have a suitable quality system in place. Established suppliers with proven quality records are registered on the Howden approved vendor list and their performance is regularly reviewed. Where possible, suppliers and manufactures are selected to maximise the local content. Where the installation is outside Australia, certain critical items over which we require close control would be manufactured in Australia.

Testing

(a) Fan Performance Test Facility

In addition to works and site contract fan performance testing of our own equipment, we are able to conduct on-site fan performance evaluation of existing equipment and to advise on any practical action which may be taken to improve the operation of a system. We can also undertake model testing for contract performance and development of fans to suit special applications and requirements within facilities located in Melbourne.

(b) Flow Model Testing

When considering complex new plant layouts and designs an accurate knowledge of flow distribution and system resistance is important. In certain cases it may be necessary to use flow-modelling methods to determine this information. Our Melbourne laboratory is fully equipped to undertake complete model flow testing and optimisation of duct arrangements, silencer systems, mine shafts, drifts etc.

(c) Acoustics

On-site investigations and testing:
For various reasons – perhaps as a result of plant up-grading and expansion, increased noise may become a problem in air and gas handling systems. We are able to undertake environmental and in-duct investigations on-site and subsequently design absorptive, reactive/dissipative or fully reactive silencers to control noise to acceptable limits. Additionally we can design and supply acoustic insulation systems to limit break-out noise from casing and duct surfaces.

Laboratory investigations: The facility has the capability to test full size modules of the largest silencers currently installed in the power industry. These tests can be carried out with flow where necessary, giving aerodynamic characteristics of the silencers as well as dynamic insertion losses at various passage velocities.



Site Management and Service

Howden Australia has a team of site Service Engineers who all have many years experience supervising the erection, commissioning and maintenance of all the Company's products. These engineers, while based in various locations around Australia are available to travel at short notice to locations anywhere in the Asia – Pacific area.

The Service Engineers are equipped with latest technology portable balancing and vibration monitoring equipment. In addition these engineers have laptop computers with general purpose software plus an industry standard scheduling package. The Service Engineers can relay data rapidly to the Sydney Head Office using modems.

Service Engineers have received specialist training in the componentry making up the Howden product. They are also familiar with the safety regulations, which are mandatory in all job sites and understand and comply with customer's reporting systems.

Most of our Service Engineers have direct experience managing large job sites both in Australia and in the Asia – Pacific region.



Quality Assurance

Howden Australia operates a third party certified (Standards Australia, Quality Assurance Services) quality assurance system in accordance with ISO 9001:2000 (Licence No. QEC1849).

The QA Department is headed by the Quality Assurance Manager who supervises the office based Quality Assurance Engineer and the full time and contracted field Inspectors.

QA System Auditing (Internal/External)

Howden Australia undergoes regular internal and independent third party QA system audits. Internal auditing is based on an annual schedule. Details of sub contractors are maintained on a vendor database and vendors are required to complete capability questionnaires including details of their quality system development.



Quality Assurance Support For Contracts

The Howden Australia QA system involves all company employees in an interactive manner. In addition to the dedicated QA/QC staff, each contract involves sales, contracts, design, manufacturing and administrative staff in a variety of standard procedures (SOPs). These include tender, contract and design reviews and inspections, non conformance investigation and other activities directly related to each individual contract.

Special processes are detailed on drawings and where appropriate as written procedures. In the case of welding procedures, detailed welding procedures/specifications are prepared. A library of special process welding procedures is maintained.

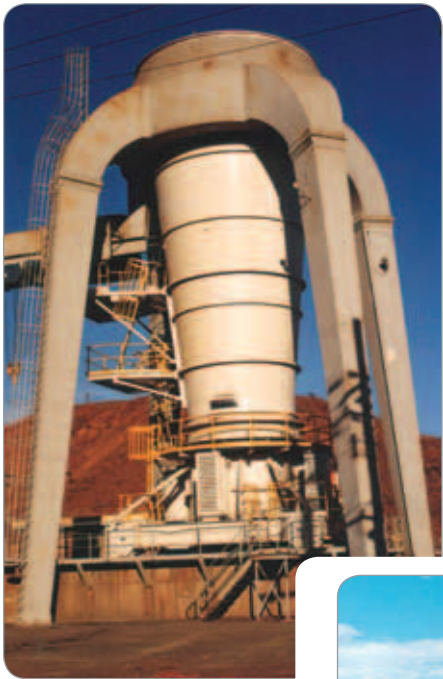
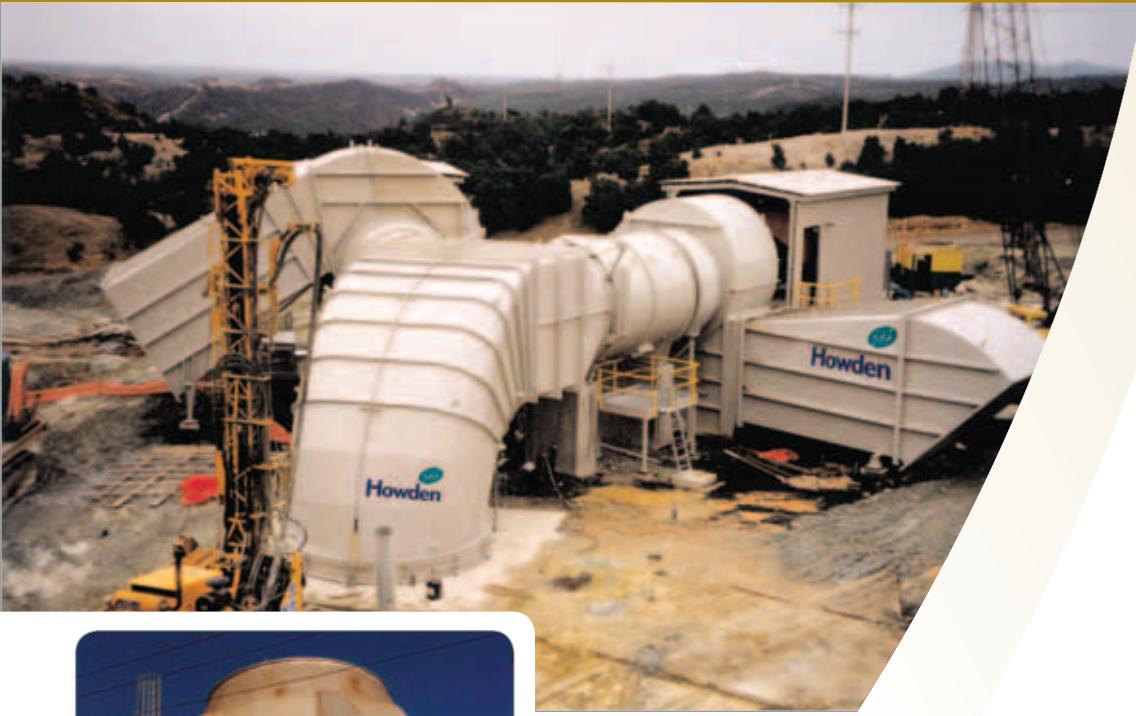

Howden Australia: Delivering Total Solutions for Mining

Mine ventilation requirements tend towards high specific speed fan designs with high efficiency and low noise characteristics. Howden is able to offer a very wide range of centrifugal, axial flow and mixed flow axial fans for these applications. Custom engineered features include blade nose wear protection and corrosion resistant materials of construction.



Features:

- Proven robust designs
- Long term reliability
- Minimum maintenance
- High efficiency
- Complete installation service
- Bend designs
- Self-closing doors
- Vertical and Horizontal axis installations

Applications:

- Up cast and down cast main surface fans
- Underground auxiliaries
- Booster fans
- Multi fan installations
- Hard rock mines
- Coal mines

Large Custom Designed Centrifugal Fans

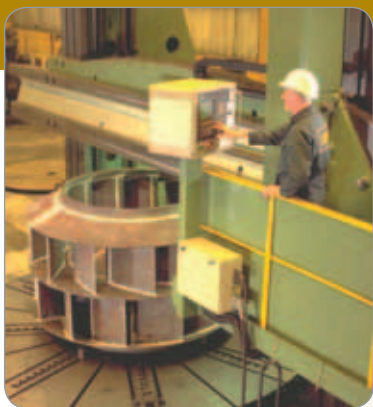

Overview

Howden offer a wide range of custom designed centrifugal fans to precisely meet the application requirements of the most demanding specifications. Scope of supply can extend to complete turnkey installations that include civil works, high voltage equipment, electrical panels, acoustic components, instrumentation and telemetry.

Various output control methods are offered to provide our clients with flexible and efficient performance. These output control methods include inlet radial vanes, inlet louvre dampers and variable speed fans. For variable speed drives, a complete fatigue analysis and life estimate can be provided.

Proprietary Howden rotor dynamics software allows for the precise calculation of forward whirl and reverse whirl critical speed margins taking into account the stiffness of every single element in the rotor support system.

In addition to conventional bearing types, Howden can also offer specialised bearing designs such as multi-lobed sleeve or pressure fed sleeve bearings. This allows our designers to optimise the bearing selection for every application. Shaft seals are custom designed to accommodate the most demanding requirements for seal effectiveness, and can include double carbon ring types with air or inert gas sealing and purging. Mechanical type and gas tight water seals can also be provided for hazardous fluid applications.

Impeller designs offered include radial, radial tip, laminar backward curved or inclined, and a range of aerofoil blade types. All blade designs can be fitted with wear protection to suit the application requirements.

Howden centrifugal fans are manufactured using the latest technology and materials to ensure structural integrity and strength, fatigue, corrosion and erosion resistance. All fans are constructed in accordance with the Howden design rules which have evolved and refined over many decades of industry experience. Materials, ranging from high tensile steel to titanium and duplex stainless steels and composites can be used. Specialised coatings and hardening processes result in fans that are rugged, reliable and efficient.

Features

- Specialised fan designs for every application
- Proven, robust and reliable design
- High efficiency
- Minimum maintenance
- Efficient output control systems
- Erosion protection options
- Corrosion resistant design options
- Low stress fatigue resistant designs
- Complete after sales service

Applications

- Boiler draught plant
- Chemical processes
- Steel making process
- High pressure blowers
- Cement plants
- Petrochemical plants
- Mine ventilation
- Heavy industry
- Pulp and paper
- Mineral processing
- High temperature fans

Large Custom Designed Howden Core Range Centrifugal Fans

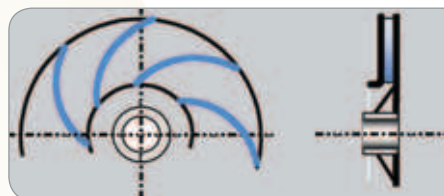

Narrow Backward Inclined Range

Description: Narrow inherently strong impellers which can run at very high speed.

Typical applications: Air blowing and process applications requiring high pressures

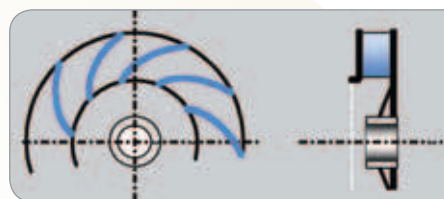

Backward Inclined Bladed Range

Description: A family of strong, highly efficient impellers optimised to maximise strength and reduce blade curvature.

Typical applications: Movement of air and gas at medium to high pressures; eg Sinter and pelletising fans Boiler primary air fans

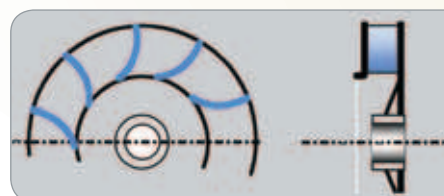

Backward Inclined Forward Range

Description: A family of backward inclined forward curved bladed impellers.

Typical applications: Used with dust laden gases where the customer specifies the use of a radial tipped fan.

Large Custom Designed Howden Core Range Centrifugal Fans (continued)



Straight Backward Inclined Bladed Range
Description: Cost effective flat plate bladed impellers that can be easily lined.
Typical applications: Air and gases containing moderate amounts of erosive particles, eg Sinter and pelletising fans, Boiler draught fans

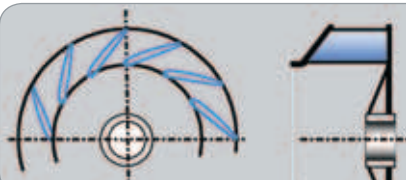

Aerofoil Bladed Range
Description: High efficient suitable for high flow rates at medium to low pressures.
Typical applications: The movement of air or gases containing moderate amounts of erosive particles, eg Boiler draught, Mine ventilation

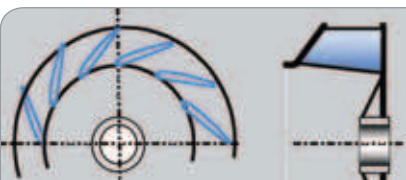

Aerofoil Bladed Range
Description: Highly efficient
Typical applications: Specifically designed for mine ventilation



Paddle Bladed Range
Description: A range of low stressed, paddle bladed fans.
Typical applications: Applications involving operation at high temperature, or with dust laden gases in Coal mill exhausters, Cement process fans

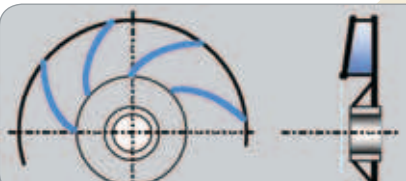

Backward Inclined Bladed Range
Description: A family of backward curved plate bladed impellers.
Typical applications: Primarily designed for cement production processes in Preheater exhaust, Kiln exhaust



Straight Backward Inclined Bladed Range
Description: A family of strong impellers with rotating inducer and rotating diffuser.
Typical applications: Applications where heavy cyclic loads are expected. Fans for Basic Oxygen Steel-making

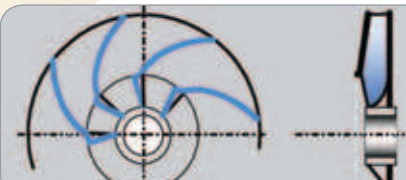

Backward Inclined Bladed Range
Description: A family of backward curved bladed impellers with rotating inducer section.
Typical applications: Applications where high pressures have to be generated in Fluidised bed boilers

Solutions for
the **Mining**
Industry



Large Custom Designed Centrifugal Fans



Fan Terminology

Adjustable pitch

The mechanism in general purpose fans that allows the pitch angle of the blades to be adjusted to exactly match the air volume flow required.

Air velocity

The velocity of an air stream is its rate of motion, expressed in litres/second. The velocity at a plane (V_x) is the average velocity throughout the entire area of the plane.

Ambient temperature

The dry-bulb temperature (t_d) is the air temperature measured by a dry temperature sensor. The temperatures relating to air density are usually referenced to the fan inlet.

The wet-bulb temperature (t_w) is the temperature measured by a temperature sensor covered by a water-moistened wick and exposed to the air in motion.

Wet-bulb depression is the difference between dry and wet bulb temperatures ($t_d - t_w$) at the same location.

Belt tube

Where a fan is mounted in the air passage way and the motor is external to the passageway, the belt tube contains the drive belt between the motor and the fan.

Density: Mass of air per unit volume (1.189kg/m^3 at 20°C and atmospheric pressure, e.g. 100kPa).

Fan

A fan is a power driven machine that moves a continuous volume of air by converting rotational mechanical energy to an increase in the total pressure of the moving air. The conversion is accomplished by changing the momentum of the fluid.

Fan characteristic

The curve which describes the fixed relationship between pressure rise and volume flow for a specific fan

Fan components

Impeller: The rotating blades on the fan shaft that exert force on the air and thus maintain the airflow at increased pressure.

Casing: The shaped casing surrounding the impeller that provides a barrier between the inlet and outlet sides of the fan.

Motor: The means of rotating the fan.

Guide vanes

Radial vanes mounted at the inlet or outlet to a fan to improve the airflow and hence the fan efficiency.

Life-cycle cost

The total cost of ownership of an item taking into account all the costs of acquisition, personnel training, operation, maintenance, modification and disposal.

Power

Air power: The product of the inlet volume flow and the fan pressure.

Fan shaft power: The mechanical power supplied to the fan shaft.

Impeller power: The mechanical power supplied to the fan impeller.

Motor output power: The shaft power output of the motor.

Pressure

Static pressure: The portion of the air pressure due to the degree of compression. If expressed as gauge pressure, it may be negative or positive.

Velocity pressure: Exists due to the rate of motion. It is always positive.

Total pressure: The air pressure due to the degree of compression and rate of motion. It is the algebraic sum of the static and velocity pressures at a point. If the air is at rest, the total pressure equals the static pressure.

Fan pressure: The difference between the fan inlet pressure and the fan outlet pressure

Specific fan power

The sum of the design total circuit watts (including all losses through switchgear and controls such as inverters) of all fans that supply air and exhaust it back to outdoors (i.e. the sum of supply and extract fans) divided by the design ventilation rate through the building.

Specific speed

The specific speed is an indication of the shape of a fan best suited to a specific duty.

Variable speed drives: An electronic device that converts the AC mains supply to DC using a rectifier and then produces a variable frequency, variable voltage at the motor terminals to enable an induction motor to be run efficiently at different speeds.

Volume flow

The volume flow rate at a plane (Q_x) is the rate of flow, expressed in litres/second, and is the product of the average velocity flow at the plane and the area of the plane.

Basic Fan Design and Efficiency

Fan design is both an art and a science. When designing efficient impellers, most manufacturers start out by testing a series of impellers with the aim of producing a set of aerodynamic shapes that:

- Cover the required pressure/volume envelope
- Develop a good efficiency across as wide a zone as possible
- Are not sensitive to small geometrical changes
- Preferably have a non-overloading power curve (where the impeller design permits)
- Are relatively easy to manufacture with a low cost (probably the most important to the manufacturer).

Although it is relatively easy to design an impeller to satisfy a particular pressure/volume duty, it is difficult to achieve this with a high efficiency while making it cost-effective to manufacture. This means that one manufacturer's fan may satisfy the duty requirements with a much higher efficiency than another manufacturer's.

The way to save energy when using fans appears simple – use more efficient fans. However, it is not

that straightforward. Modern higher efficiency motors have a relatively flat efficiency curve with load, and improving the motor efficiency means improving the efficiency over the whole operating field. The same does not apply to fans – the efficiency curve is far from constant and there can be a difference of 30% between peak and low efficiency in the fan's working range. In addition, the energy use of similar fans performing the same duty but from different manufacturers can vary by up to 30%. It is therefore important to select a fan that is operating as near to its peak efficiency as possible.

Fan specifications should stipulate the use of both a high efficiency fan and a higher efficiency motor (either classified as Eff 1 or one eligible for enhanced capital allowances) to achieve maximum energy savings during the operational life of the equipment. Advice on motor selection is given in Section 3.1.1.

When selecting a fan and specifying a fan installation, it is also important to consider whole life costs. These consist of the initial cost of the fan, energy costs, plant life expectancy, the cost of maintenance and other operational issues, and disposal costs. Appendix B explains how to calculate whole life cost.

Solutions for the Mining Industry

Selection of the Fan for the System

Fan selection entails matching the fan performance curve to the system resistance curve to find the fan that will develop the equivalent and necessary pressure to meet the system requirements, i.e. the fan will deliver the designed flow rate when installed in the system.

The graph demonstrates the problems that can occur if the system designer fails to ensure that the fan characteristic and the system characteristic are suitably matched.

The dotted line to the left of the design system characteristic shows a pressure drop in the system that is 40% above the design value. This results in lower volume flow, increased pressure and the danger of the fan failing to operate at all because it is close to the point of stall.

The dotted line to the right of the design system characteristic shows a pressure drop 40% lower than the design value. Here, the fan operates at reduced efficiency, thus delivering an excess volume of air.

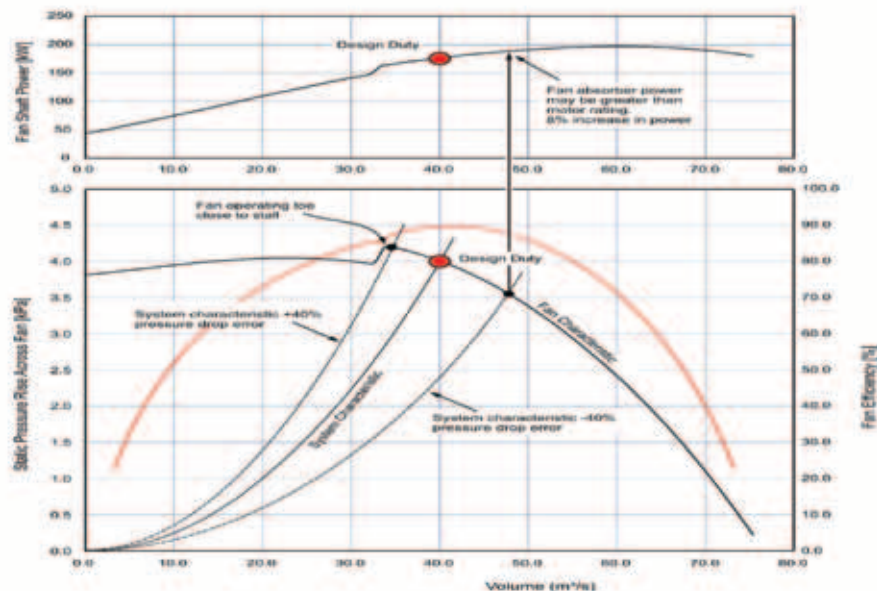

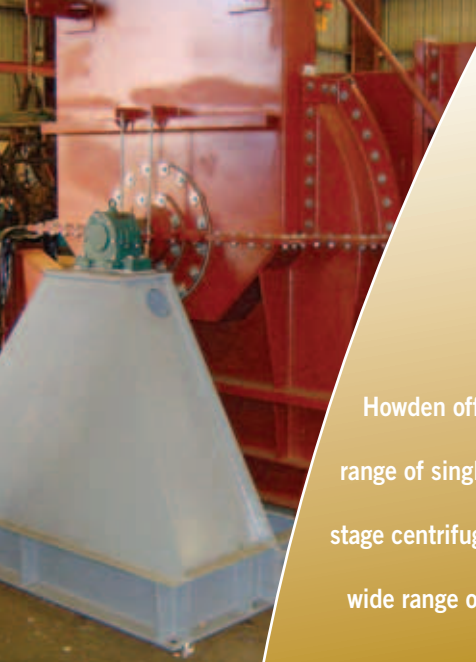

Howden offer a comprehensive range of single stage and multi stage centrifugal blowers for a wide range of applications.



Type RRO Centrifugal Blowers

The Type RRO single and two stage centrifugal turbo blowers have been developed to satisfy the needs of the chemical, petrochemical and process industries for compact, high efficiency installations. The overhung impellers are machined from solid forgings, and the blower casings are manufactured from heavy castings that are accurately machined to fine tolerances.

The basic blower design incorporates a rotor and integral gearbox assembly that is custom engineered to ensure that all bearing, stress and rotor dynamic considerations are satisfied. Depending on application requirements, anti-friction bearings or advanced technology tilting pad thrust bearings and tilting pad journal bearings are supplied for the high speed rotor.

High efficiency open type radial bladed or backward curved blade impeller designs are available. Both impeller types are provided with inlet inducer vanes. Blower output control is primarily effected by inlet radial vane controls. Variable vane diffuser controls that deliver very high efficiencies over a much wider flow range than can be achieved with only inlet radial vane controls are available as an option.

The complete unit comprising blower, gearbox, control panel, drive motor and integral lubrication unit are skid mounted for ease of transport and installation.

The RRO blowers can be manufactured from a wide range of corrosion, abrasion and temperature resistant materials to satisfy specific process conditions, and can also be supplied to API Standards if required.

Type RRC Centrifugal Blowers

The Type RRC multi stage centrifugal blowers satisfy a need for very low specific speed blowers in mineral processing and chemical industries. The blowers are generally directly coupled to two pole induction motors, and offer the advantages of low noise and low cost together with high operating efficiencies. Maintenance is simplified, and these units do not require any special skills other than those normally associated with fan maintenance and service.

The complete blower assembly and drive motor are carried on a single integral base unit which simplifies transport and installation.

The blowers incorporate fully fabricated impellers and casings, and this important feature allows for an extremely wide range of readily welded materials to be considered for construction.

The impeller inlets and stationary inlet cones are machined to ensure optimum aerodynamic performance, and each impeller stage is provided with a set of inlet control vanes that provide high efficiencies over a wide operating range.

In many applications, the Type RRC blowers represent a practical alternative to positive displacement blowers, and are far more efficient and generate less noise than comparable PD blowers. Typical applications include flotation cells, waste water treatment, fluidizing blowers and combustion air blowers

The Fan Laws

The performance of geometrically similar fans of different sizes or speeds can be predicted accurately enough for practical purposes using the Fan Laws. These laws apply to the same point of operation on the fan characteristic. Where a fan's characteristic is known, the laws can also be used to predict a new pressure volume characteristic curve at a different impeller diameter or speed.

The Fan Laws are most often used to calculate the changes in flow rate, pressure and power of a fan when the size, rotational speed or gas density is changed.

For a system where there is no change in fan size or in density of the air or gas, and pressure loss increases in proportion to the square of the flow:

Inlet volume (Q) varies in proportion to the speed of the fan (n), i.e. $Q \propto n$.

Fan total pressure and static pressure vary as the square of the fan speed, i.e. $p_t \propto n^2$ or $p_s \propto n^2$.

Air power (P) (total and static) and the impeller power vary as the cube of the fan speed, i.e. $P \propto n^3$.

For geometrically similar airways, the Fan Laws can be used to calculate changes in flow rate, pressure and power when the size, rotational speed or gas density changes. Figure F shows how the effects of a fan speed increasing or decreasing can be evaluated.

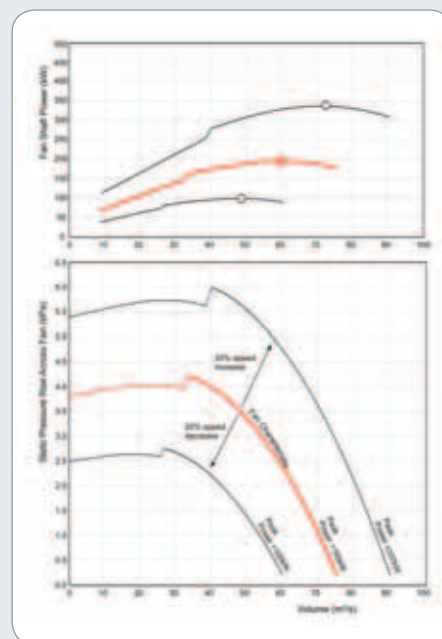

Figure F: Demonstration of the Fan Laws

System resistance laws

When air is moved through a ducted system, the energy transferred to the air by the fan is progressively lost by:

- Friction of the air against the duct walls
- Turbulence at bends, dampers and changes of duct section
- Through heaters, filters or other items of equipment in the system.

The loss of pressure due to all these sources, known as the system resistance, is for all practical purposes proportional to the square of the velocity at the point of loss.

Therefore, for a fixed system, it may be said that the pressure (p) required to pass a given volume of air (Q) through the system will vary as the square of the volume flow rate, i.e. $p \propto Q^2$. This means that, for a fixed system, the greater the airflow, the more pressure is required. Hence, to double the airflow, four times as much pressure has to be produced by the fan.

For example, if the initial flow rate is 6m³/second at a pressure of 3kPa and it is required to double this to 12m³/second:

$$\frac{p_1}{p_2} = \frac{(Q_1)^2}{(Q_2)^2}$$

$$p_2 = \frac{p_1 (Q_2)^2}{(Q_1)^2} \quad \text{i.e. } p_2 = \frac{3 \times 12^2}{6^2} = 12\text{kPa}$$

This is true only for a fixed system and a constant air density. Should the system be altered (e.g. by closure of a damper), the above laws do not apply directly.

Static, Velocity and Total Pressure

Atmospheric air experiences a pressure caused by the weight of the air above. This is the barometric pressure (p₀) and is quite substantial, being typically 100 kilopascals (kPa).

If air is blown into a balloon, it can be described as being 'under pressure'; the 'skin' of the balloon applies the pressure. The air inside the balloon experiences a greater pressure than the atmospheric air outside, though the difference will be relatively small, e.g. 105kPa compared with 100kPa in the atmosphere.

The term 'pressure' describes both that inside and outside the balloon, assuming the air to be still in both cases. The term absolute pressure is used for clarity; thus, in the example the absolute pressure inside the balloon is 105kPa, and outside the balloon it is 100kPa.

In the example with the balloon, the air is not moving and therefore there is no velocity pressure component to take into account. The static pressure therefore equals the total pressure.

Static pressure (p_s)

The difference between the absolute pressure at the point under consideration and the atmospheric pressure is what is important in fan engineering. This is termed the static pressure and corresponds to the potential energy of the air stream. In the example of the balloon above, the static pressure is 5kPa (105 – 100). Static pressure is shown as positive when the absolute pressure is greater than atmospheric pressure, and negative when it is below atmospheric pressure.

Static pressure can also be described as the pressure exerted against the side of the duct measured at right angles to the direction of flow. Working with static pressures rather than absolute pressures compensates for natural variations in atmospheric pressure. For example, if the barometric pressure had been 96kPa, then blowing up the balloon to 101kPa would have required the same effort and produced the same static pressure in the balloon as before (5kPa). Calculations in terms of static pressure can only be independent of atmospheric pressure if the static pressure is relatively small compared with atmospheric pressure. Air can then be treated as an incompressible fluid.

Velocity pressure (p_v)

Velocity pressure is an important quantity to which all the pressure and drag effects of a moving air stream can be related. What counts is the velocity of the body relative to the undisturbed air. Velocity pressure corresponds to the kinetic energy of the air stream.

$$p_v = \frac{1}{2} \rho v^2 \quad \text{where } \rho = \text{density of air or gas and } v = \text{velocity of air or gas}$$

The movement of air or gas exerts a force on an object in its path. This is mainly because the pressure on the windward side is greater than that on the leeward side. The air or gas is not stopped by the object, but flows round it. The air is brought to rest at one point on the surface of the object.

Total pressure (p_t)

The sum of the static pressure and the velocity pressure at any point in the air is called the total pressure.

$$p_t = p_s + p_v = p_s + \frac{1}{2} \rho v^2$$

To raise the pressure of the air or gas, work must be done on it, i.e. the air or gas must absorb energy. In the example above, we need to use our lungs or a balloon pump to increase the pressure in the balloon. Conversely, if the pressure falls, the air or gas must give out energy.



Solutions for
the Mining
Industry

Centrifugal Fans

- Small and Medium Boiler draft
- Small and Medium Heavy duty industrial
- Exhaust and material handling
- Corrosive and abrasive applications
- Plug type and exhaust for industrial applications
- Single width Vee-driven
- Double width Vee-driven
- Single width direct drive
- High Pressure
- Rugged Duty

Blowers

- Small and Medium Centrifugal single and multi-stage
- Cast iron high pressure centrifugal
- Channel blowers

Accessories

- Inlet Vane Control
- Silencers
- Heavy duty industrial Dampers
- Louvre dampers
- Opposed blade dampers
- Radial vane control
- Screens
- Spring or RIS mounts

Services

- Breakdown services
- Complete rotor replacement
- Rotor repairs
- Planned maintenance
- Rebuilding or upgrading existing fans
- Spare parts

Handing
As viewed from the drive side



Standard Fan Range or Custom Engineered Fan?

Many medium industrial fans available today are selected from standard ranges of pre-engineered designs and sizes. The manufacturing process economies resulting from the limited engineering and design requirements for standard fans are substantial, and allow the cost of manufacture and delivery period to be greatly reduced.

The concept of a pre-engineered standard fan range may lead to technical compromise in the interests of maintaining a "standard" product. For this reason, the purchaser/ user should carefully consider all aspects of ownership before making the decision to purchase a standard fan.

Applications that are unusual, or of a critical nature in the process, should be subjected to careful examination.

Common compromises include:

- **Bearing selections that are marginal, prone to skidding, overheating and premature failure.**
- **Shaft couplings or belt drives that are marginal and prone to premature failure..**
- **Overstressed Impellers with unsatisfactory safety margins.**
- **Inadequate rotor dynamics ie., low critical speed margins.**
- **Inadequate rotor support systems.**

The compromises that have been built into the pre-engineered fan can include high power consumption, mechanical unreliability, excessive noise and sensitivity to out of balance forces that will result in frequent and costly nuisance trips.

A custom engineered fan ensures that every element of the unit is precisely designed and optimized to meet detailed specifications for stress, corrosion, erosion, equipment life requirements, safety and material properties.

- **The design of fan shafts takes into account the stiffness of all elements of the rotor support system, including Clients foundations. This ensures that the rotor is not sensitive to out of balance forces.**
- **A detailed impeller stress analysis is carried out to ensure that safety considerations are satisfied. This includes fatigue analysis to ensure adequate stop/start cycles for the proposed operating regime.**
- **Material selections and weld procedures appropriate for the application are checked and specified in detail before manufacture proceeds.**
- **Bearings are engineered to suit the exact requirements for each application.**

Conveying Velocities (m/s)

Castor beans.	25.4
Cement.	35.6
Coal, Powdered.	20.3
Rubber.	22.9
Cork, Ground	15.2
Corn	8.4
Cotton.	22.9
Iron Oxide.	33.0
Knots, blocks	25.4
Limestone, pulverized	25.4
Oats	22.9
Paper	25.4
Rags.	22.9
Salt.	27.9
Sand.	35.6
Sawdust, dry.	15.2
Shavings.	17.8
Wheat.	29.5
Wool	25.4
Vegetable pulp, dry.	22.9

Controlling Flow Rates Through a Fan System

It is often necessary to control the rate at which air is moved through a fan system. This may be:

- **A once-only correction to compensate for initial errors in calculation**
- **An intermittent control to give, for example, a summer and winter condition**
- **A continuously variable adjustment to maintain an environment or to supply a process.**

The fan designer's job is to produce fans that achieve the highest possible part-load efficiency.

The rate of airflow through a system is governed by the intersection of the system resistance line and the fan performance characteristic. Control can be achieved by changing the effective resistance of the system or altering the performance characteristic of the fan. The method chosen will depend largely on the savings in absorbed power at reduced flow rates balanced against initial cost.



Control by system design

The simplest means of adjustment is to use a valve or damper at a suitable point in the ducting system (see Figure D). Closing the damper increases the resistance to flow and the quantity of air falls as dictated by the fan characteristic. Dampers can either be operated manually or using a control system.

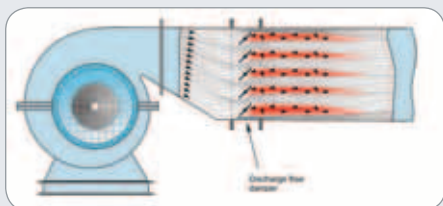

Figure D Fan discharge flow damper

Control by fan characteristic

Continuously variable controls allow the fan to operate at the highest possible efficiency even at part-loads. However, they function only if the system resistance curve follows the square law and goes through points of zero pressure and flow. If the system does not follow the square law, reducing the fan speed will result in the fan reaching a stall condition with poor efficiency.

There are three main types of continuous control of fan performance.

1. Speed control

One of the most efficient methods of controlling the performance of a fan is to vary its running speed. When working in a constant pressure duct system (i.e. square law system resistance), the point of operation on the fan's characteristic is unchanged as the speed varies. This has the advantage of maintaining the fan's efficiency, resulting in a corresponding maximum drop in power consumption and fan noise level as the speed is reduced (see Figure 17).

This method provides a suitable means of controlling the speed of the fan, either by varying the speed of the prime mover or by changing the ratio of the drive.

Examples of speed control methods include:

- Multispeed or variable speed electric motors
- Variable speed gearbox
- Fluid coupling
- Magnetic coupling
- Variable ratio pulleys and belt drive.

When assessing the power saving using these methods, it is necessary to take account of the change in efficiency of the prime mover and drive (this may vary with speed or load). If electrical, magnetic or mechanical slip is involved, the overall effect is usually to reduce the power input to the prime mover as the square of the speed while its output to the fan impeller varies as the cube of the speed; the efficiency of the speed conversion is equal to the ratio of output and input signals.

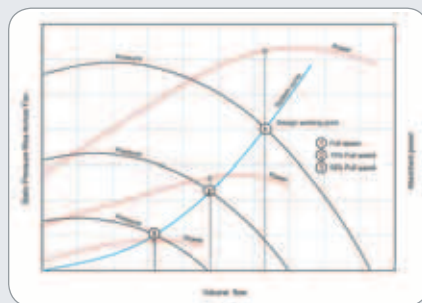

Figure E Flow control by speed regulation

2. Inlet vane control

This method involves introducing specially designed adjustable vanes into the air stream entering the fan inlet, to generate a swirl of air in the direction of the impeller rotation. This reduces the performance capability of the fan, which shows progressively reduced pressure/volume and power curves as the vanes are closed. This in turn moves the working point down the system resistance curve.

3. Blade angle control (axial fans only)

This very efficient method, which is currently confined to axial fans, involves adjusting the blade pitch angle while the fan is running. The angles of all the blades are altered simultaneously.

Factors affecting the choice of control method

The first step is to assess the saving in power over the life of the machine. The next step is to compare these savings against initial outlay and maintenance costs, while bearing in mind the degree of control required and the frequency of operation.

Factors that can influence the choice of control method include:

- Initial manufacturing and installation cost
- Maintenance and replacement cost
- Power saved
- Degree of control required (stepped or continuous)
- Accuracy and repeatability of the control settings
- Range of flow over which control is required
- Temperature, toxicity or corrosiveness of gas handled
- Period of time over which each setting is effective
- The control system itself.

Sizing and Selection of Motors

Improved sizing can significantly reduce both the capital and running costs of electric motors. Motors are often rated well above the power levels at which they operate. Modern motors are designed for maximum efficiency at 75% full load, although there is minimal variation in efficiency between 50% and 100% load. Significant reductions in efficiency occur at 25% load or less.

As an example, a basic duty may suggest a delivered power requirement of 7.5kW. Typically, the designer may specify a 10% design margin and the project engineer may apply a further 10% contingency. Applying these two 10% increases would suggest a specification of 9.1kW. However, as 9.1kW is not a standard rating, an 11kW motor would have to be selected. For the duty required, the selected motor would actually operate at two-thirds or less of its rated output.

Oversizing motors increases:

- The capital cost of the motor
- The capital cost of matching switchgear and cabling
- The capital cost of power factor correction equipment
- The running costs due to lower efficiency.

Higher efficiency motors (HEMs) are designed to minimise the inherent losses and can save, on average, 3% of energy consumption compared with standard motors. They are also quieter.

Fixed and Statically Adjustable Pitch Axial Flow Fans

Howden fixed pitch axial flow fans combine the proven technology of high efficiency Howden axial fan designs Type AFN with low maintenance design features to suit the mining and process industries. Howden axial flow fans irrespective of size are designed to correct aerodynamic principles for low loss entry, stator vane geometry and diffusion so that performance is optimised.

Fixed pitch impellers of welded construction are normally supplied in the cases where the hub is too small to accept the blade clamping mechanism required for blade adjustment. These fixed impeller range from 1200mm to 750mm diameter.

Stall Warning Note:

Stall is an aerodynamic problem that can occur on a fan system and is related to operation of fans at a flow and pressure which cause flow to separate from the blade surface. Large axial flow fans can fail completely if run continuously in stall for several hours and it is possible that some would not last even this long depending on the energy levels which in turn relate to the fan design and speed. It is particularly important in fan systems where the flow and pressure may vary regularly that care is taken to ensure the fan will operate away from its Stall region.

Mining Applications.

Manually adjustable pitch axials are commonly used in mine ventilation systems where there are planned step changes in the system flow and pressure requirements during the life of the mine. Just prior to the required time for more or less ventilation, the fan must be stopped and the blade pitch adjusted by accessing the impeller. It is not normally necessary to re-balance the fan after a pitch change.

An alternative to pitch change which may suit some applications is that the number of blades may be changed to increase or decrease the blade solidity. The number of blades effects the peak pressure capability of the fan. The third operational parameter which may be adjusted in combination with the above is the motor speed.

1. Primary Ventilation Fans

Howden fans are designed with utmost reliability in mind and incorporate many safety features to protect operational and maintenance personnel from personal injury. Any Mine Ventilation engineer knows the importance of reliable operation of the main ventilation fans. If the ventilation fans stop for any reason in an unplanned way, the air supply underground is stopped and the lives of miners are put at risk. A Mine Manager knows the cost of lost production time and an unplanned fan shutdown may effect overall production for the month, quarter or even year if it is down for long enough. Howden reliable engineering together with certified spare parts and back up service ensure that there are no unplanned shutdowns and minimal required shutdowns during the life of the fan. Main ventilation fans may be installed on the surface or underground as required in either vertical, horizontal or intermediate angle position.

2. Auxiliary Ventilation Fans

Howden has a range of auxiliary mine ventilation fans to suit every underground application including:

- Underground booster between downcomer and exhaust air systems.
- Mobile auxiliary fans for trailer or skid mounts.
- Roof mounted exhauster for branch roadways or development areas of the mine.

Upgrade Possibilities

Due to its experience and dedication to Research and Development, Howden has developed a number of upgrade options which can be engineered into existing fans:

- Stall prevention systems
- Pre-rotators to improve pressure performance
- Alternative blade profiles
- Alternative blade materials
- Upgrade control and instrumentation including the addition of flow measurement.

Industries which utilise the Howden axial fan are:

MINING

- Main ventilation fans both surface and underground
- Underground booster fans and auxiliary fans
- Dedusting fans

PROCESS INDUSTRIES

- Fume exhaust fans
- In line booster Fans

The manually adjustable axial fan allows the flexibility of Offline adjustment to suit the process and system requirements which may be experienced in a planned or unplanned way, while minimising the capital cost compared to a variable pitch in motion axial fan. It is vitally important in the purchase of a manually adjustable axial fan that the range of possible operating conditions is considered carefully. It is especially important to decide on the maximum operating point so that the fan's motor size is selected to cover all operating conditions up to that point.

Howden axial fans are specially designed to customer specifications and optional supply items include:

- Turnkey design, build install both mechanical and electrical
- Mine Ventilation system shaft top bend or portal connector
- Drive system including Motor and Controls.
- Parallel fan system including adapter to vent shaft .
- Flow Measurement system
- Stall warning systems.
- Stall Prevention Systems
- Instrumentation for vibration, temperature and pressure.
- Silencing equipment for environmental noise control.

Solutions for the Mining Industry



◀ Main Ventilation Fan During Installation



◀ Main Fan on Skid Mounts

Fan Energy Savings

Energy

This is calculated from the flow rate and fan pressure, then brought to present day values and integrated over its working life. The input power is included in the equation.

$$W \text{ (power input) watts} = \frac{Q \times p_f}{\rho_f \times \rho_m \times \rho_t \times \rho_c}$$

where:

- Q = air or gas flow rate in m³/second
- p_f = fan (total) pressure in kPa
- ρ_f = fan (total) efficiency expressed as a decimal
- ρ_m = motor efficiency expressed as a decimal
- ρ_t = transmission efficiency expressed as a decimal
- ρ_c = controls efficiency expressed as a decimal.

In many systems (e.g. variable air volume, mechanical draught), the flow rate varies continuously. To calculate the total kWh, it is important to know the percentage of time at which the plant operates at its design maximum and the general pattern of output versus time.

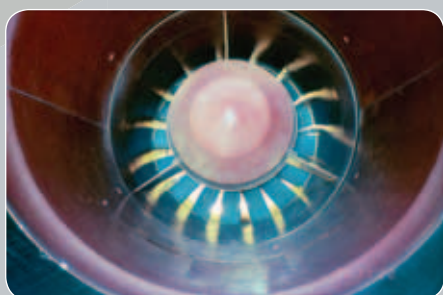

Area	Check	Possible improvements
Application	Is the system doing useful work?	Significant energy savings can be achieved by stopping the fan when the ventilation is not required.
Design	Has the fan been sited to reduce system resistance?	Poor design can mean the ductwork has unnecessary bends and fittings, or even that the length of ductwork is excessive. Careful consideration of the fan location at the design stage can lead to significant energy savings.
Performance	Can a control method be used to match the fan speed to demand?	Many control systems are available. By monitoring the demand, the airflow rate can be adjusted to meet the demand, e.g. using a variable speed drive (VSD). For larger axial fans, adjusting the pitch of the blades is a common method of adjusting the airflow. Savings can be as high as 30%. Note: Where there is no need to adjust the airflow rate, installing a VSD could increase energy consumption by 5%.
Fan	If it is a centrifugal fan, is it running in wrong direction or is a wrong-handed impeller fitted?	Change the fan direction or replace the impeller.
	If it is a centrifugal fan, is it handling an incorrect volume of air?	Change the impeller to reduce energy consumption.
	Is a complete change of fan justified to obtain a significant improvement in fan and system efficiency?	Significant savings can be achieved by selecting efficient fans that are sized as accurately as possible to work at the correct flow near their point of most efficient operation.
	Is the swirl at the inlet the opposite direction to the fan rotation?	Straighten out the flow in the inlet with fixed vanes.
	Are turning vanes fitted where there is a duct bend close to the inlet?	Install vanes if not fitted.
	Is a transition piece fitted where the duct size reduces?	Install a transition piece if not fitted.
	Are flexible connections fitted correctly with no offset or slack?	Carry out a visual inspection to ensure correct connection.
Fan outlet	If there are bends in the ductwork close to the outlet, are these radius bends with splitters?	It is generally good practice not to have bends close to the outlet.
	If the fans are an axial or propeller type, are guide vanes fitted to provide energy recovery?	Guide vanes should be considered when the pressure is above 750 pascals.
	Is the swirl at the inlet in the opposite direction to the fan rotation?	Motor overload is possible. Consider installing upstream straightening vanes.
Motor	Is the motor oversized?	Losses are often caused by too large a safety margin being introduced during the design and installation stages, resulting in the specification of too large a motor. Modern motors give good performance from 50–100% of rated load, making selection a little easier; however, selection of the right motor remains important.
	Is a three-phase motor operating on all three phases?	Check for faulty wiring and fuses.
	Is an AC motor running below its normal speed due to a winding or starting fault?	Check the connection diagram with the motor.
	Can the drive mechanism be improved?	Changing from a vee-belt to a direct drive or flat belt drive can save energy.
	Is a higher efficiency motor (HEM) being used?	Apart from very low duty applications, it is always worth fitting HEMs that are classified as Eff 1 or that appear on the Energy Technology List (see www.eca.gov.uk).
Ducting	Is the ducting tubular with a large cross-sectional area?	If so, this should be kept to a minimum. Installing tubular ducting instead of standard rectangular ducting and ensuring that the cross-sectional area is as large as possible will produce a low velocity system with a low pressure drop, thus maximising efficiency.
	Has the pressure drop achieved using dampers during balancing been minimised?	Good design should ensure that all legs have equal pressure losses. After installation, a ventilation system must be balanced to ensure that all areas receive the ventilation required. Care should be taken when selecting dampers for balancing to minimise the pressure drop.
Site performance	Have checks been carried out throughout the site on airflow rate, pressure and absorbed power?	Possible actions identified by a site test are change of fan speed, new fan drive, change of fan motor (e.g. to a higher efficiency type or a different power rating), change of fan size and capacity control to meet varying load demand.

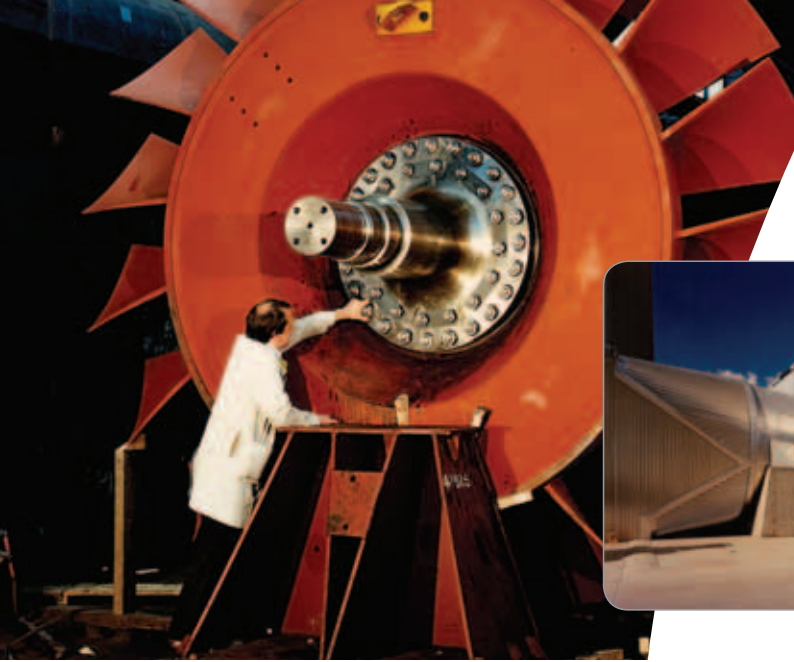

Mixed Flow Axial Fans

The impulse bladed mixed flow axial fan provides a considerable advantage in size and weight over comparable centrifugal and axial flow fans. The simple robust plate bladed impeller is ideal for handling dust laden gases at elevated temperatures. The design delivers substantially higher pressure coefficients than conventional reaction bladed axial flow fans. This allows much lower impeller tip speeds and smaller impeller diameters to be used with a consequent reduction in noise and wear.

Instead of accurately profiled aerofoil section blades, the impeller makes use of constant thickness curved steel plate blades which are fixed to a conical hub. The annular cross sectional area through the blade passage is therefore reducing as the flow progresses through the impeller passage.

The reduction in annular area accelerates the flow axially and radially through the blade passage. These effects, together with the high rotational component imparted by the impeller, combine to produce a very high energy flow leaving the impeller. As the flow is accelerated through the impeller passages, there is no significant static pressure rise across the impeller, and the increased velocity pressure is recovered by the downstream stator vanes and the fan diffuser section

As blade shape and profile are not critical, the fans are not sensitive to wear on the blade profile.

The fan performance is not noticeably degraded by erosion or corrosion, and the fan will maintain high operational efficiencies over a long period of time without the need to replace blades.

Impulse bladed mixed flow fans are controlled by inlet radial vane controls similar to those used with centrifugal fans. This form of control is extremely effective, and allows rapid changes in fan output in response to process demands. If required, the fan can be supplied with a passive stabilizing chamber which modifies the fan performance characteristic. This feature makes it possible to eliminate the stall characteristic. The aerodynamic design of the stabilizing chamber can be adjusted to allow the available pressure at low flow to be controlled to suit specific process requirements.

Howden Australia has supplied more than forty mixed flow fans up to 5000mm diameter. Motor powers have ranged from 350kW to over 9000kW.

Mixed flow fans are the most technically effective axial fan design for Primary mine ventilation and Booster applications as the design is compact and mechanically robust. The smaller physical size, robust construction, lower noise and higher rotor structural integrity also make them ideal in underground booster applications.

Design to Minimise Pressure Drop

The characteristics of any fan are affected by the installation to which it is connected. This may be ductwork or another means of conducting the air through the space. The effect of the ductwork on the fan performance is called the system effect. Ideally, this will ensure that the fan performance is optimised, but it may reduce the expected fan performance.

When designing ductwork systems and selecting fans, it is important to minimise the influence of the installation as this can adversely affect the aerodynamic performance. A major design issue, when considering the system pressure drop, is where to locate the fan: the fan should be located as close as possible to the application to minimise the length of ductwork. In addition, pressure losses can be reduced by:

- Good design at entry from and discharge to the atmosphere
- Minimising friction in duct lengths
- Close attention to detail at changes of duct areas and shape
- Minimising bends and changes in direction
- Using radius bends in preference to right-angled bends
- Good design when dividing flow into branches
- Using Y-junctions in preference to T-junctions
- In rectangular ductwork, keeping the aspect ratio as near to one as possible
- Avoiding obstructions,
- Good design and installation of filters, heaters, coolers, grilles and louvres
- Keeping the change of pressure between atmospheric and that at the inlet and outlet as low as possible.

Features
• Long service life
• Non-fouling design
• Minimum maintenance
• Easy cleaning
• Low pressure drop
• Flexibility of design
• Suitable for high temperatures
• Broad attenuation range
• Available in various materials

Applications
• Induced draught fan system
• Contaminated gas streams
• Saturated gas streams
• Corrosive gas streams
• High temperatures
• Steam vent systems
• Mine ventilation



The Problem

Conventional absorptive silencers have been used successfully over the years to handle clean air. However, when used in gas streams containing particulate matter and moisture, accumulation of dust in the plate perforations and absorptive material has resulted in a rapid deterioration of attenuation.

The Answer

Howden pure reactive attenuators are based on the Helmholtz resonator principle, and are ideally suited to handling contaminated air and gases, especially where moisture carry-over is a problem. A series of tuned resonator cavities attenuates excessive and unwanted noise in all gas movement and stream silencing applications. Since there are no perforated plates or absorption material to deteriorate, the maximum service is obtained over the life of the plant with minimum maintenance. A range of special materials is available for corrosive or high temperature applications.

Howden Australia has developed reactive silencer designs that allow the silencer to cover a broader range of sound attenuation that have previously restricted the use of these types of silencers.

Reactive-Dissipative Attenuators

Howden reactive dissipative attenuators provide a lower cost alternative for handling contaminated air and gas streams by incorporating both reactive chambers for attenuation of specific frequencies and absorptive fill material for broad band attenuation.

The splitters consist of a series of tuned acoustic chambers. Sound waves corresponding to the design frequencies are reflected out-of-phase to the incoming sound waves. As the reflected and incoming sound waves are directly opposite in their wave patterns, they have a cancelling effect on each other, reducing noise levels.

The upstream faces of the chambers are lined with absorptive fibreglass material to reduce broadband noise. The fibreglass is situated out of the air stream, shielding it from contamination by particulate matter.

Site Management

Delays and long outage times are extremely costly, pre-assembled parts and effective site installation ensures safe and short access time. Howden completed the site installation of a Reactive Silencer at the 660MW per Boiler Eraring Power Station in NSW Australia (see picture) in 5 weeks in 1977. Recent test early 2000 confirmed that the aerodynamic and acoustics are still within the original specified limits.

Fans System Resistance

An air system may either consist of just a fan with ducting, or it may be more complicated with additional components (as shown in Figure A). The fan is the component that provides energy to the air stream to overcome the resistance to flow of the other components in the system.

Every system has a resistance to flow; this usually differs from other systems and depends on the individual components from which it is assembled. The characteristic curve of a typical 'fixed system' is a parabola given by the relationship:

$$p \propto Q^2 \text{ where } p = \text{pressure and } Q = \text{flow rate}$$

For a fixed system, an increase or decrease in the system resistance results in an increase or decrease in the volume flow rate along the given system curve. Figure 9 shows an example of fan characteristics at fixed speed

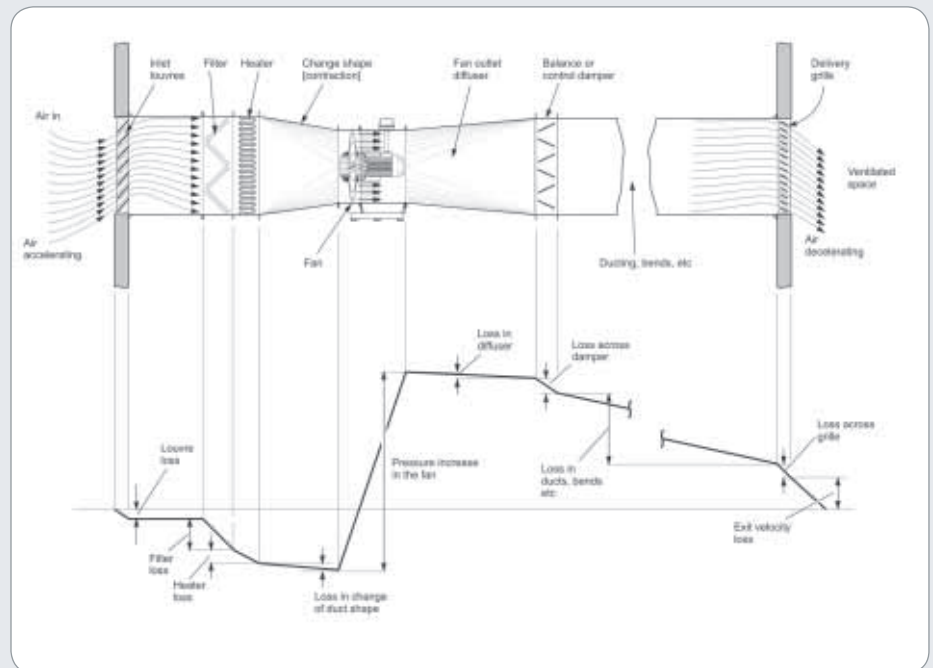

Figure A: Fans System Resistance

Solutions for the Mining Industry

Profiles

- Medium Pressure Profile
- High Pressure Profile
- Volume Profile

Materials

- Cast Aluminium
- Forged Aluminium
- Nodular Cast Iron
- Cast Steel
- Cast Nickel Alloy

Erosion Shields

- Stainless steel with hard chromium layer

Coating

Howden can offer various blade coatings depending on specific customer requirements for erosive and corrosive environments.

Howden introduced the first VP axial flow fan for power generation in 1951. Since then Howden has manufactured more than 2000 VP axials ranging from 100 to 12000 kW and from 1000mm to 5300mm diameter.

Following the introduction of the variable pitch axial flow fan for power stations, continued research and development ensures that Howden's VP axial fans lead the market mechanically aerodynamically and in performance. Extensive model tests in our own AMCA and VDI laboratories have fully optimised the airways of our fans. Howden offers the most efficient fans on the market and continuously seeks to develop new efficiency levels and improvements.

Every rotor passes a full speed running test in the workshop prior to shipment and is supplied fully balanced. Each individual blade is balanced and can

be replaced on site without rebalancing the complete rotor. Howden has established mechanical engineering, manufacturing and maintenance principles which today form the standard on all major markets.

The Howden VP axials are customised fans based on standard components. This ensures an unbeaten flexibility in design. Howden VP axials can be installed for all applications and in all positions in power stations and heavy industry. Howden can supply a wide range of blade materials, with or without erosion shields, several types of main bearing assemblies, different types of stall protection and several airways with different aerodynamic characteristics.

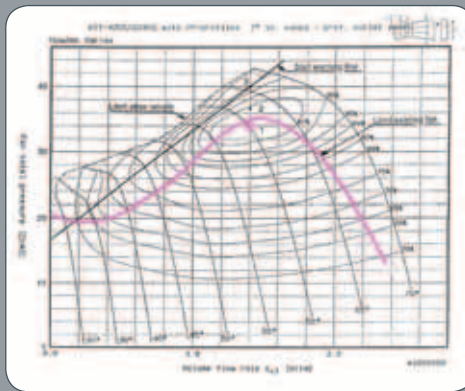
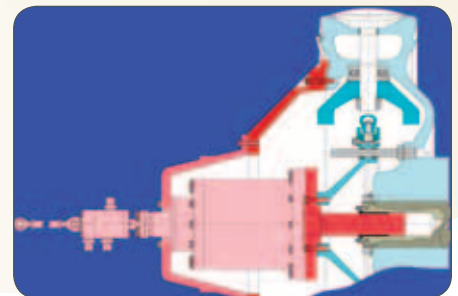
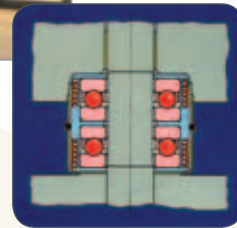

◀ Benefit of High Pressure Blade Profile



High Efficiency Howden Donkin Turbo Compressor Centrifugal Turbo Impeller



Howden, Bryan Donkin Sirocco, Reavell, Neu Sofrair and Berry all renowned worldwide for their technical expertise in the design and manufacture of fans and blowers – combine to form an enviable resource of experience for customer confidence.

The Howden Donkin range of integrally geared high efficiency turbo compressors has been developed over 40 years for use in a broad range of process applications world wide.

Key Features of the Howden Donkin Range

1. Capacity Control System and Actuator
2. Flexible Connection
3. Turbo Compressor
4. Safety and Monitoring Devices
5. Drive Motor
6. Local Control Panel
7. Baseplate acting as oil reservoir
8. Anti-vibration mountings

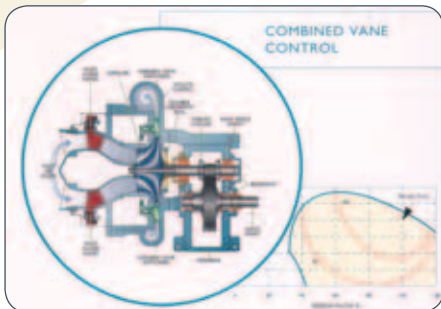

Centrifugal Turbo Impeller

- Induced Backward Curve Profile
- Precision Machined from Solid Forging
- Optimum Performance evolved through Computational Fluid Dynamic Design
- High Stability

Upgrade Possibilities

Due to Howden commitment to ongoing product improvements, there are operational and control upgrades available for Howden Blowers in the following areas:

- Control panel conversions to modern electronics with PLC interface
- Flow control systems for increased efficiency
- Impeller material
- Variable Speed motors for multi load operation.

Capacity Control Systems

Three Types of Control Systems are available:

1. Inlet Guide Vane Control (IGV)
2. Inlet Throttling -Pre-rotation of the air intake
3. Variable Vane Diffusers (VVD)
4. Combined Vane Control (CVC)

Main Markets & Applications

Waste Water Treatment

- Air blowers associated with the biological treatment of effluent in municipal Sewage Treatment Plants

Industrial Effluent Treatment

- Air blowers associated with the biological treatment of effluent within Industrial Plants

Flue Gas Desulphurisation

- Oxidation air blowers associated with the cleaning of flue gases produced within power and heavy industry.

Furnace/Smelter/Reactor Air Supply

- Air blowers providing combustion or reaction air primarily for the petrochemical and metals industries

Carbon Black Plant

- Air blowers providing combustion air for the associated furnaces.

Fermentation

- Air blowers associated with biochemical fermentation within Pharmaceutical and Food Additive industry.

Sulphur Recovery

- Air blowers providing reaction air for the catalytic recovery of sulphur within the petrochem industry.

Sulphuric Acid Plant

- Combustion air blowers and Process gas mixture cleaning, sometimes combined.

Fan Remote Control Monitor

Data Monitor

This stand-alone unit is battery backed and has up to 24 single ended analog inputs that can be software configured and combined to allow the sensors to be powered and logged. The unit has a burst mode capability that will allow a stream of high-speed data to be sent back for in-depth analysis on the vibration signals.

If there is more than 1 fan the units can be networked. Any one of the Data Monitors can be used to collect and send all the data via a modem to the host computer, or link into an existing network with Internet facilities. Mobile phone [GSM] units can be used if there are no phone lines available.

Innovative solutions from the global leader in air and gas handling



Adding Value to Excellence

Top: Remote monitoring can be used to trend data and identify when the equipment should be inspected.

Bottom: Fans at inaccessible sites can now be monitored with minimal costs using a satellite based mobile phone link with up to 24 channels of data available to inspect at any time. Automatic posting to the fan web page whenever levels reach predetermined settings.

Engineering Capabilities

Howden Australia offers the benefit of a Sydney based professional engineering team who are able to provide customers with local expertise in advanced fan and rotary air heater technology. Our resources include the use of finite element analysis (FEA), unique Howden proprietary rotor dynamics software and shaft analysis programs, computational fluid dynamics (CFD) and other techniques that ensure that all our products embody state of the art techniques in the design of rotating machines.

Finite element analysis is frequently used in the areas of material selection, stress evaluation, natural frequency and sensitivity studies, fatigue life calculations and failure investigation. This work is carried out in accordance with acceptance standards developed globally by the Howden Group.

Howden rotor dynamics software is used to calculate shaft transverse critical speeds and shaft torsional critical speeds. Evaluation includes the complete rotor support system comprising foundations,

bearing-pedestals, bearing-housings and lubricant-film stiffness. Actual foundation stiffness values are used to determine design resonant speeds, and will provide an accurate assessment of the fan rotor system. This process ensures that the calculated data is precise and does not incorporate any inaccurate or unjustified stiffness assumptions relating to elements within the rotor support system. Such assumptions can result in an inadequate rotor support system that may operate with an unsafe critical speed ratio or be sensitive to out of balance forces.

This service can be related to:

- Impeller design and durability.
- Fan system natural frequency determination and modification.
- Plant noise level evaluations and solutions.
- Performance testing and upgrading.
- Failure investigation.
- Fan system variable speed conversion evaluation and design.
- Improvement in fan and blower reliability.

Howden Australia has the backing of the full Howden Group resources for air and gas handling solutions.

Plant Upgrades, Research and Development

The Howden Group of Companies has been in the forefront of air and gas handling technology throughout the world for more than one hundred and fifty years. The key to establishing and maintaining this standard of excellence has been the Howden commitment to research and development.

Howden Australia has always been able to provide R&D service to the local industry in Australia and Asia Pacific. Howden Australia has many world class achievements which testify to this fact and continues to do so in a changing industry. Howden Australia has by far the largest installed base in the region with a growing demand for life extensions and optimizing/ increasing these plants. We continue to maintain a staff of skilled professional engineers with expertise in fan engineering, rotor dynamics, acoustics, vibration and systems/process engineering as well as a fully equipped laboratory to undertake in-depth aerodynamic, thermal heat exchange and acoustic investigations associated with air and gas handling and environmental noise problems and will continue to offer practical applications and solutions.

Howden Australia is able to undertake wide-ranging investigations into plant operation, and is able to offer practical guaranteed solutions for capacity upgrades or power reduction programs. This work involves modifications to fans, air and gas handling systems and air preheaters.

Examples of our R&D efforts:

The design and development by Howden Australia of mixed flow induced draught fans with stall stabilising technology represented a World first. This technology is now widely used in the Australian power generation industry and is gaining acceptance overseas.

Howden Australia pioneered the application of fabric filters to large power generation applications worldwide, and projects undertaken in Australia and South Africa are still amongst the largest fabric filters ever constructed.

Howden Australia developed the design and manufacture of broad band reactive silencers and secured Patents for much of this technology. These silencers can be manufactured from a very wide range of materials and can accommodate heavily contaminated gases at high temperatures and in corrosive environments.

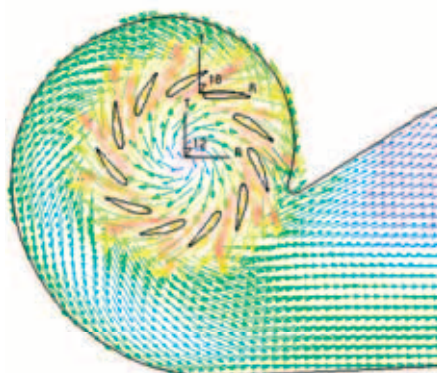

Site Services

Howden is a multinational air and gas handling organisation with many product and service related brands, with a dominating global and regional Fan and Reactive Silencer experience of 150 years and the largest installed base. As a result it has gained unrivalled product and service knowledge. The Australian installed base exceeds 20,000 installations and about 10,000 in South East and East Asia at any kind of process and operation plant that handles air and gas movements or heat exchange. The experience has been reflected in outstanding performance and extremely reliable products. All our products are good for service lives of 20 to 40 years and many will be or have already been in excess of 50 to 70 years.

Howden recognised from the beginning that a custom-made product integrated in large capital expensive plant requires effective and exceptional service and maintenance support. We constantly try to stay ahead using the available technology to the extent that the ever-increasing demand and awareness of plant performance, upgrade options and reliability is for several generations the natural work culture for the Howden staff and basis of the organisation structure.

OUR SITE SERVICES ACTIVITIES

- Re-builds to original specification and upgrade of any air and gas movement equipment to latest technology
- Upgrade for different output and changed gas medium
- Performance Upgrades
- Turnkey supply of design, material, site management, site installation
- Site surveys, inspection and plant evaluation
- Preventive maintenance and maintenance advise
- Medium and long-term planned and supportive unplanned outages
- Performance and function tests and the relevant problem solution/ implementation
- Custom-made replacement spares, upgrade spares for any air and gas movement equipment as well as rotary airheaters.
- On-site Balancing
- Site Supervision

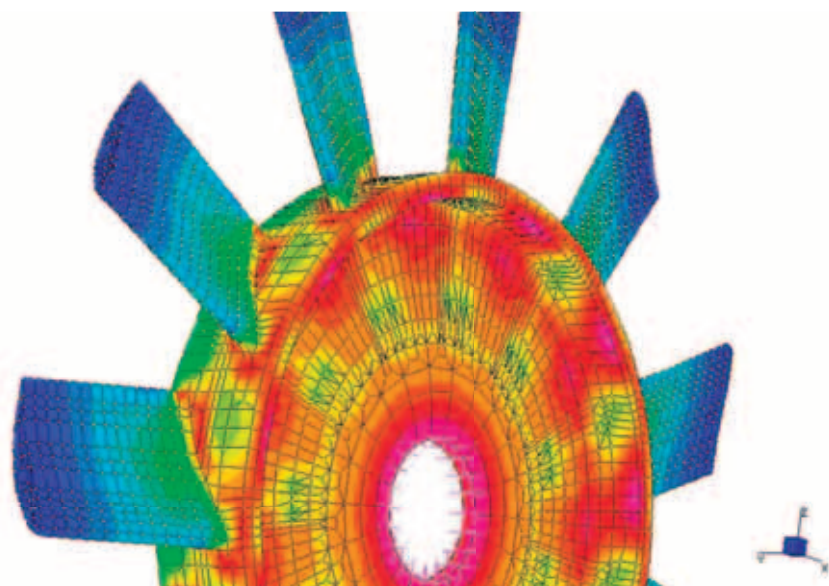

Site Fan Installation and Set-up

Even after a manufacturer has designed, built and tested a fan that satisfies the client's performance requirements (i.e. pressure, volume, power absorbed, etc.), significant problems can arise if the fan is incorrectly installed (the fan supplier is often not responsible for installation). Certain aspects, such as uniform tip clearance on an axial fan and inlet cone positioning and penetration on a centrifugal fan, can have a significant impact on the installed performance and efficiency of the fan. Installation effects on fan performance

The installation of ductwork close to a fan has a significant effect on the performance of both the fan and the ductwork. Because the magnitude of this effect is often unknown, contingencies may be added to the calculated fan performance to allow for shortfalls in performance due to installation effects. This can result in increased capital and running costs, and a system that is not operating at its design condition.

Assuming the fan is rated correctly, the three most common causes of poor fan performance due to the effects of the installation are:

- **Non-uniform inlet velocity (see figure B)**
- **Swirl at the inlet (see figure C)**
- **Improper outlet (see figure D)**

Inlet flow distribution is paramount. If the flow is badly distributed, fan performance will be significantly reduced. The ductwork adjacent to the fan can have a considerable effect on the fan performance, and the fan manufacturer and system designer should discuss this issue. Example problems include restrictions caused by fan inlets located too close to walls, obstructions and the effects of plenums.

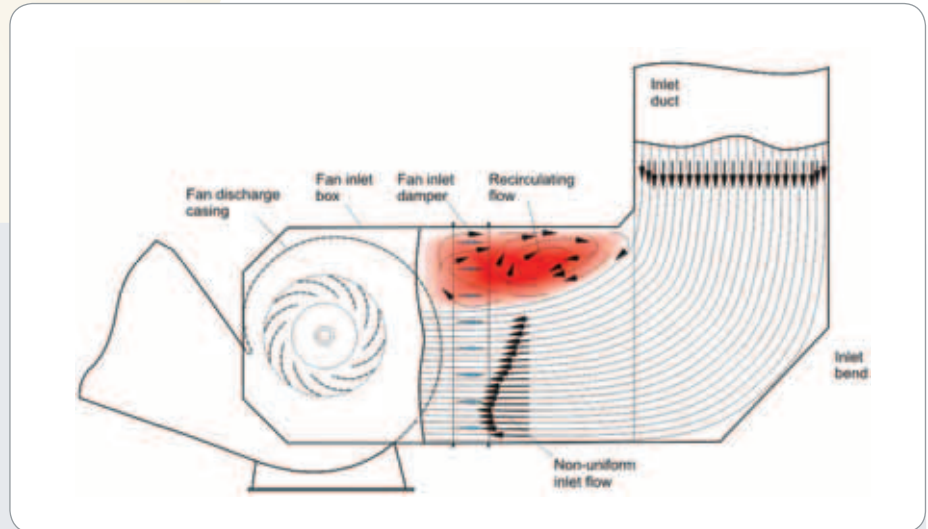

Figure B: Non-uniform inlet velocity

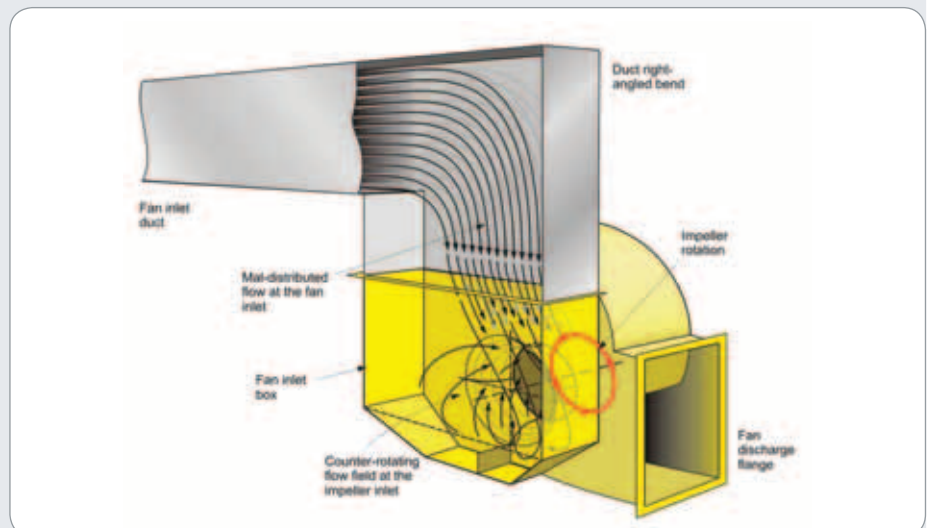

Figure C: Swirl at the inlet

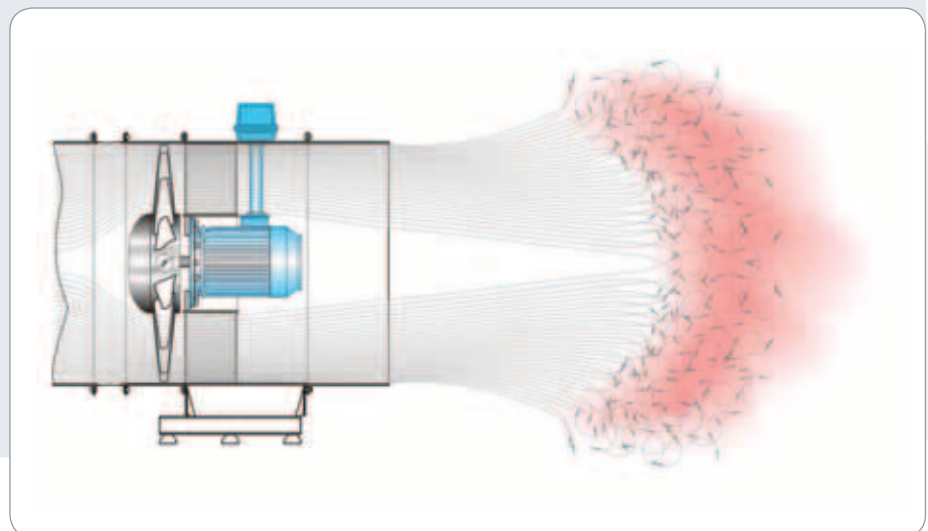

Figure D: Improper outlet

We are the last resort for air and gas movement solutions. Why not try us first.

Howden Australia is open to discuss the possibility of total plant maintenance ownership or once off maintenance. However we strongly recommend maintenance-consistency to develop trend readings, achieve preventive maintenance and pro-actively adapt to plant/ operation changes. Howden Australia has also developed maintenance standard procedures and reports whereby enabling you to compare your plant with other plants and their experience across the globe.

Maintenance:

Our business is solely about air and gas handling. We are proven to be able to maintain, upgrade and retrofit air and gas movement equipment fast and cost effectively. Howden can organise the real required maintenance on a pre determined fixed cost.

There are four common Fan and Airheater maintenance segments, which vary in volume, frequency, accessibility and availability.

Planned routine and preventative maintenance

- Monthly check and cleaning/adjusting of the filtration, movable linkages and vibration monitor.
- Minor overhauls (yearly...).
- Major overhauls (every 5 years...)

Unplanned maintenance

- Emergency breakdown. Respond at 24 hours availability.
- Overhaul at longer off-load periods on an 24 hours/ round a clock basis
- Dynamic balance and laser alignment.

Off site maintenance

- Overhaul equipment at Howden works near plant or in Australia.

Spare supply

- Supply of all planned (routine or preventative) Fan spares.
- Supply of emergency spares.
- Stock management of spares off or/and on site.

Solution Engineering starts and ends by eliminating other possibilities.

Solution engineering is often a integrated part of research and development (see included section)

Example:

- Vibration readings
- Analyse of vibration readings and trend prediction as well as solution engineering
- Bearing inspection and maintains
- Check holding down bolts
- Verify synchronisation of Fan control
- General lubrication and function check
- Check of control instruments
- General observation
- NDT of critical stressed rotating part

Upgrades and Retrofits and Upgraded Spares

The historical evolution of technology requires a continuous need for improvement. Howden probably has the most collected upgrade and retrofit data bank in the air and gas movement industry. The unique strength is available for any plant operator. Howden Australia implemented many thousand modification, upgrades and retrofits of small and large scale. A few are presented in this brochure.

Replacement Spares

Fans are designed with minimum wear and tear. However some parts are exposed to erosive mediums and temperatures which even the most affordable material cannot resist indefinitely. Replacement spares are mostly custom-made without stock keeping with the best available wear protection. These spares often require months of material sourcing and manufacturing. Spares may be evaluated by risk, if not replaced, to predict life expectancy but also affect the overall operation performance. Some parts may need to be stocked according to life expectancy. We label spares in categories of strategic value, general maintenance requirement and wear and tear replacements. Howden has the ability to supply spares of most non-Howden supplied equipment to our Howden Product Standard.

General Spare List for Centrifugal Fans

3.2.1	Shaft	
3.2.1.1	Shaft key to impeller hub and coupling hub Strategic Spare
3.2.1.2	New Shaft Strategic Spare
3.2.1.3	Shaft bearing collars, drive and non-drive end Strategic Spare
3.2.1.4	Rebuilding of bearing landings and collars Strategic Spare
3.2.2	Impeller	
3.2.2.1	New impeller Strategic Spare
3.2.2.2	Protection liners for nose, blade side and centre sheets Maintenance Trend Spare
3.2.3	Bearings drive end and non-drive end	
3.2.3.1	Sleeve bearings Maintenance Spare
3.2.3.2	New bearing housing, end cover Strategic Spare
3.2.3.3	Re-metal of bearing sleeves Maintenance Repair Spare
3.2.3.4	Supply of shaft seals Maintenance Spare
3.2.3.5	New shaft seal housings Strategic Spare
3.2.4	Roller bearings	
3.2.4.1	New roller bearings Maintenance Spare
3.2.4.2	New bearing housings Strategic Spare
3.2.4.3	Bearing housing seal Maintenance Spare
3.2.5	Coupling	
3.2.5.1	New coupling halves Strategic Spare
3.2.5.2	Coupling springs Maintenance Spare
3.2.5.3	Coupling spacers Maintenance Spare
3.2.5.4	Coupling Rubber Maintenance Spare
3.2.6	Motor	
3.2.6.1	Refurbish fan motor bearings Maintenance Spare
3.2.7	Casing	
3.2.7.1	Replace shaft seals Maintenance Spare
3.2.7.2	Replace shaft seal housing Strategic Spare
3.2.7.3	Refurbish/replace inlet cone Maintenance Spare
3.2.8	Radial Vane Control (RVC)	
3.2.8.1	Replace vane blades Strategic Spare
3.2.8.2	Replace vane shafts (Inner and Outer) Maintenance Spare
3.2.8.3	Replace vane bushes/bearings (inner and Outer) Maintenance Spare
3.2.8.4	Overhaul control ring Maintenance Spare
3.2.8.5	Overhaul control ring guides rollers and bearings Maintenance Spare
3.2.8.6	Overhaul RVC Actuator Maintenance Spare
3.2.8.7	Overhaul RVC Actuator arm and base plate Maintenance Spare
3.2.9	Damper	
3.2.9.1	Replace Damper blades Strategic Spare
3.2.9.2	Replace damper blade shafts Maintenance Spare
3.2.9.3	Replace damper bearings/bushes Maintenance Spare
3.2.9.4	Overhaul damper arm and actuator base Maintenance Spare
3.2.9.5	Overhaul damper actuator Maintenance Spare
3.2.10	Lubrication system	
3.2.10.1	Supply lube pumps electrically driven Strategic Spare
3.2.10.2	Supply lube pumps mechanically driven Strategic Spare
3.2.10.3	Supply filter units (dual system) Maintenance Spare
3.2.10.4	Supply of oil coolers Maintenance Spare
3.2.11	Temperature control and vibration monitor	
3.2.11.1	Thermocouple Maintenance Spare
3.2.11.2	Vibration Monitor Maintenance Spare



Howden Australia

www.howden.com.au

Unit 23, 38 - 46 South Street
Rydalmere-Sydney NSW 2116
Australia

Tel. +61 2 8844 9100
Fax +61 2 8844 9101

Aust. Toll Free 1 800 337 357
US Toll Free 866 213 6237
email: solutions@howden.com.au

Solutions for
the Mining
Industry