

Fans and Heat Exchangers

MODIFICATION OF A QUAD-SECTOR AIR PREHEATER AT SHENTOU POWER STATION IN CHINA HAS RESULTED IN A SIGNIFICANT REDUCTION IN AIR LEAKAGE AND IN FAN POWER.

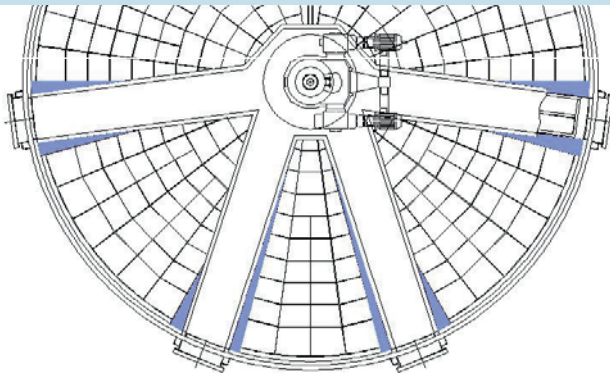

Extending the sector plates improved the sealing.

Air preheaters at Shentou power station were permitting excessive amounts of leakage, due to fly ash entrained in the flue gas causing significant erosion of the sealing surfaces. Modification including the conversion to the Howden VN sealing system reduced leakage from 17% to 6% with a consequent saving in fan power of 1600kW. After more than a year's operation, the rate of erosion has been considerably reduced.

Shentou No 2 power station in Shanxi province, China, consists of 2 x 500MW units firing local coal. The high quantity of ash in the flue gas was a major cause of erosion which resulted in the leakage in the two quad-sector regenerative air preheaters being significantly higher than the design value. In addition, it was identified that the parallel sector plate arrangement did not fully provide effective sealing.

The station decided that many features of the Howden VN design should be fitted to the existing air preheaters, initially on one unit. The radial and axial sector-plates separating primary and secondary air had to be replaced because of erosion, it was therefore decided to widen the sector-plates in conjunction with increasing the number of radial plates in the rotor to achieve double sealing along the full radius. The reduction in free rotor area due to the widening was not significant. The effect of double sealing is to reduce the pressure drop across each seal, which in turn lowers the velocity of the particles hitting the sector-plates and other components, thus significantly reducing wear.

Erosion of the drive rack on the rotor rim was also a problem. To alleviate this the heater was converted to the Howden center drive system. With this configuration, all drive components are located on the top of the shaft, outside the gas stream. A further benefit is that the axial seals can run the full length of the rotor, which improves the overall sealing.

Basic Data	Before	After
Secondary air leakage	17%	6%
Primary air at fan	Datum	-25%
PA fan current	320A	240A
Total fan power	Datum	-1600kW

Fans and Heat Exchangers Experience

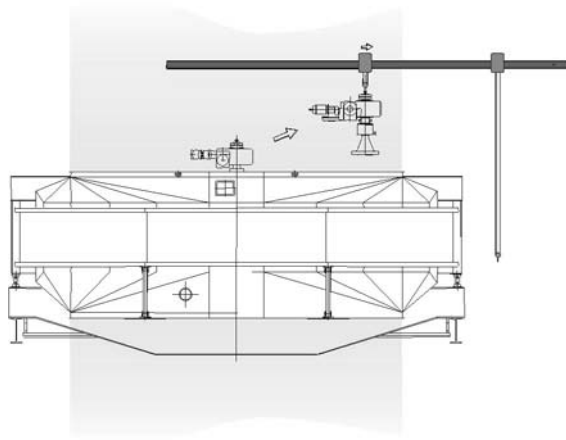

With the Howden centre drive system, maintenance is simplified.

A third problem that the modifications solved was that of dust ingress behind the adjustable sector plates, which made it difficult to move them. This in turn affected the leakage control system. As the Howden VN does not rely on the use of moving sector plates this problem could no longer occur.

Work commenced on site in June 1997, and finished in August that year. The results were dramatic. Air to gas leakage was reduced from 17% to less than 6%. Primary air to secondary air leakage was reduced by 25%, which was reflected in the reduction of motor current from 320 to 240A per fan. This was equivalent to savings of 1200kW per boiler, and when the FD and ID fans were also considered, the power savings totalled 1600kW.

More than a year after commissioning the leakage has remained within the guarantee figure of 6% and the air preheater has met its availability targets. The rate of erosion of the sector plates and other components has been reduced.

Following successful operation, a repeat order for the other boiler was received in late 1998

Maintenance

As the following components are not required for the Howden VN design of airheater, the maintenance activities associated with them are not required.

- Pin rack for the drive
- Bearing lubrication system
- Moving sector plates or seals
- Sensors, actuators and linkages

As the sealing system does not rely on sector plates or seals which continually adjust to compensate for rotor deflection, there is very little possibility of mechanical damage to the seals and the time between seal replacement is significantly increased.

Howden

Old Govan Road
Renfrew
United Kingdom

Tel +44 141 885 2890
Fax +44 141 885 2887
Email: marketing@howden.com
Web: www.howden.com

